



VIBROSYSTEM



STATOR WINDING VIBRATION MEASURING SYSTEMS

“IS STATOR WINDING CONDITION A MAJOR CONCERN ON YOUR GENERATORS?”

Early detection of winding vibration is a key component in preventing forced outages caused by insulation system failures. Our Fiber Optic Accelerometer (FOA™) and Stator Bar Vibration (SBV™) products' are designed to address such concern.



Abrasion of a bar insulation from in-slot vibration (radial) against stator lamination compared to a new bar.



Deposit of oil mist on end-windings and stator core at extremities contributing to bar vibration.



Paint flaking on end-windings caused by vibration contacts against laminations.

Problems related to stator windings are a major cause of generator forced outages. Electrical insulation is one of the most important parameters influencing generator reliability.

Most winding problems originate from vibration of end-windings or bars in the slots. Voltage stress, mechanical forces and thermal effects continuously undermine insulation integrity, end-winding bracing and stator wedging. As shrinkage and looseness develop, winding vibration occurs. Over time, other destructive effects can result.

Being able to easily detect and monitor winding vibration from the onset permits prevention of such destructive effects. On-line monitoring of end-winding and in-slot bar vibration clearly shows if levels are acceptable or not. Simple data analysis permits trending of the aging process before serious damage and breakdown entail repair outages. Action can be timely planned or deferred to optimize the plant generation availability.

COMMON PROBLEMS ASSOCIATED WITH WINDING VIBRATION

Vibration is a symptom of:

- Operating Conditions:
Mechanical Stress (RPM),
Electrical Stress (100 or 120 Hz),
Thermal Cycling
- Bad Wedging of Bars and
Blocking/Bracing of End-windings
- Gravitational Force acting on
End-winding Baskets
- Fatigue of End-winding
Support System
- Moisture Contamination

Vibration is both Symptom and Cause of:

- Loosening of Stator Bar Wedging
and Side Packing Systems
- Loosening of End-winding
Blocking and Bracing Systems
- Abrasion and Reduction of Insulation

Vibration is Direct or Indirect Cause of:

- Fatigue of Components
- Loss of Ground Contact Between
Bars and Stator Core
- Insulation Cracking
- Broken Binding Ties and
Ripple Springs
- Delamination
- Reduced Electrical and Mechanical
Strength of Insulation
- Discharges
(Slot, Partial, End-windings)
- Puncture of Insulation
- Overheating
- Material Powdering
- Cooling Leaks in Windings
(Water or Hydrogen)

WINDING VIBRATION IS A RELIABLE INDICATOR OF GENERATOR CONDITION

- Early Detection of Anomalies and Troubles to Prevent Forced Outages
- Safe and Transparent to Machine Operation and Personnel
- Proven High Precision and Effective Technologies

FOA™

END-WINDING VIBRATION MEASURING SYSTEM

Breakthrough for Electrically Hostile, High Voltage and Explosive Environments

The FOA™ optical accelerometer[†] is ideal for all applications where conventional accelerometers are not suitable, such as end-winding vibration measurement in turbogenerators, hydroelectric pump/generators and large electric motors.

Long end-windings are especially prone to vibration induced by electromagnetic, mechanical and gravitational forces occurring at twice the synchronous frequency (100 or 120 Hz). High vibration leads to deterioration and failure of the support and insulation systems, which ultimately cause forced outages or extensive out-of-service repairs.

The FOA-100 unibody design[†] (sensing head, fiber optic cable, sealed feedthrough connector) and optical signal channel[†] ensure excellent electrical insulation, immunity to interference, unobtrusiveness to machine operation, and safety of personnel. Its calibrated bias voltage output allows quick and easy evaluation of the vibration levels. Typical FOA installation on turbogenerator includes identical layouts of 7 accelerometers at both turbine and exciter ends: one per phase circuit in radial axis, one in tangential axis.

SBV™

IN-SLOT STATOR BAR VIBRATION MEASURING SYSTEM

Knowledge of Wedge Tightness Without Stopping Machine

The SBV™ system provides valuable information on in-slot bar vibration while generating. Trending bar vibration gives a good insight on winding condition and wedging system tightness, and enables timely planning of maintenance or rewedging needs.

In-slot bar vibration responds primarily to electromagnetic forces and thermal cycling. As material ages, shrinks and settles in, slackness develops within the slots, allowing the coils to vibrate. Abrasion of insulation against stator laminations undermines its integrity, allowing destructive effects to appear. By defining critical operating conditions and avoiding excessive vibration, one can prevent or defer such effects.

A range of SBV sensors[†] is available to suit different machine types and installation needs. Our latest model installs flat on a wedge to measure bar movement behind it. Other models replace part of a wedge or mount near the bar exiting from the stator core. SBV sensors are normally installed on the high voltage bar of each phase circuit at both turbine and exciter ends (typically 12 sensors per turbogenerator). A specially designed feedthrough connector is used on hydrogen-cooled turbogenerators. The LIN-200 series conditioner provides a 4 to 20 mA linearized output of raw bar vibration.

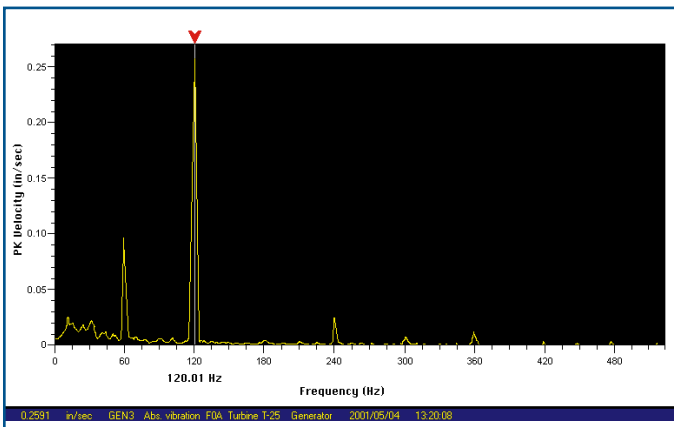

Spectrum graph of end-winding vibration in radial axis from a 870-MW hydrogen-cooled turbogenerator.

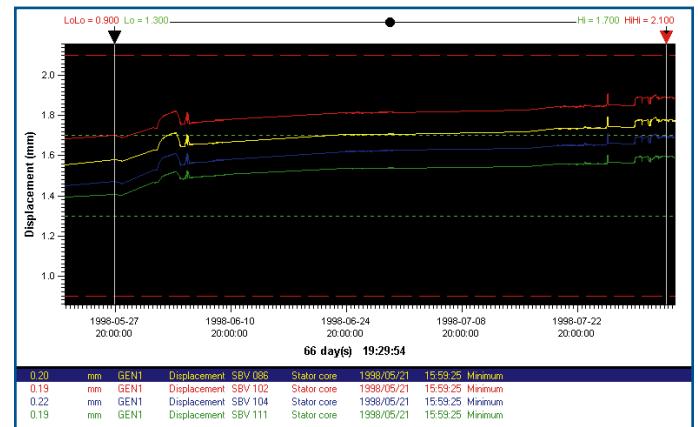

Trends of in-slot bar positions as they settle over a two month period following machine initial start.



FOA INSTALLATION ON END-WINDINGS OF TURBOGENERATOR

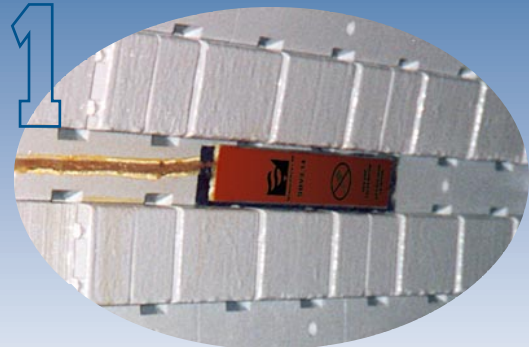

SBV INSTALLATION ON A WEDGE OF TURBOGENERATOR

- Technology adopted by major manufacturers after extensive in-plant and field tests
- Excellent electrical insulation (>27 kVrms) between sensor head and instrumentation
- Unibody design: lightweight sensor head of non-conducting components, optical signal channel, feedthrough connector with built-in conditioner
- Unaffected by magnetic and electrical fields
- Low transversal sensitivity, very good thermal stability
- Frequency range: 30 to 350 Hz, customizable up to 950 Hz
- Dynamic range: 0 to 40 g
(1 mm [39.4 mils] peak-peak @ 100 Hz)
- Sensitivity: 100 mV/g
- Bias voltage output: +6 VDC ±4 VAC
- Fiber optic cable length: 10 m (32.8 ft)
- Minimum bending radius: 80 mm (3.15 in.)
- Monitoring generators since 1991
- High immunity to deposits of carbon dust, dirt and oil, and to strong magnetic field, EMI and RFI
- Noncontact measurement, patented capacitive measuring technology'
- No on-site calibration required
- High sensitivity: $\geq 2 \mu\text{m}$ (0.08 mil) @ static gap of 1.5 mm (60 mils)
- Measuring ranges: 0.1 to 1 mm (4 to 40 mils) or 0.5 to 2.5 mm (20 to 100 mils)
- 3 installation techniques: on-wedge, in-slot, bridge-mount
- Feedthrough connector: leak-tight seal for a wide range of pressures (up to 120 psi on thread side) and temperatures (0° to 100° C [32° to 212° F])
- 4 to 20 mA linearized analog output of raw bar vibration/movement relative to stator core

END CROSS-SECTION OF GENERATOR

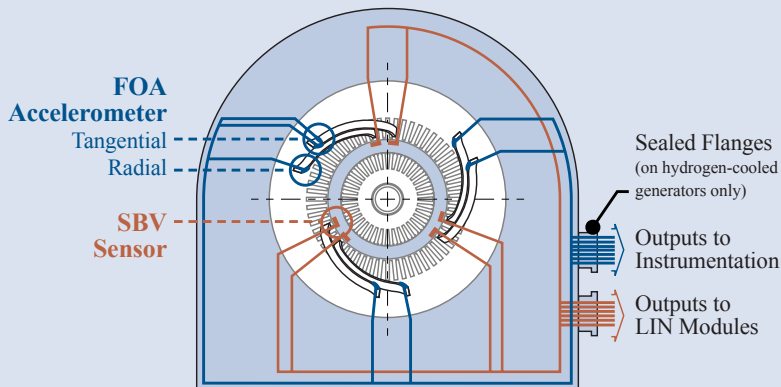

LONGITUDINAL CROSS-SECTION OF GENERATOR (SAME LAYOUT AT BOTH ENDS)

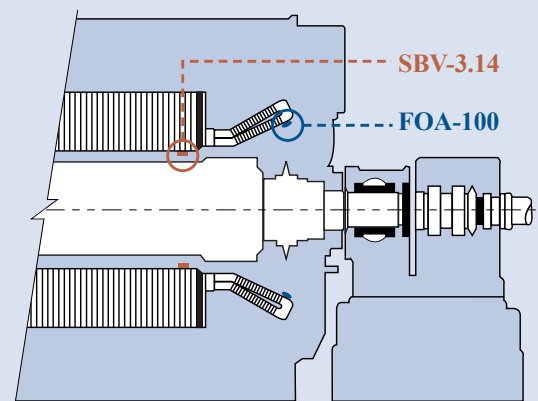
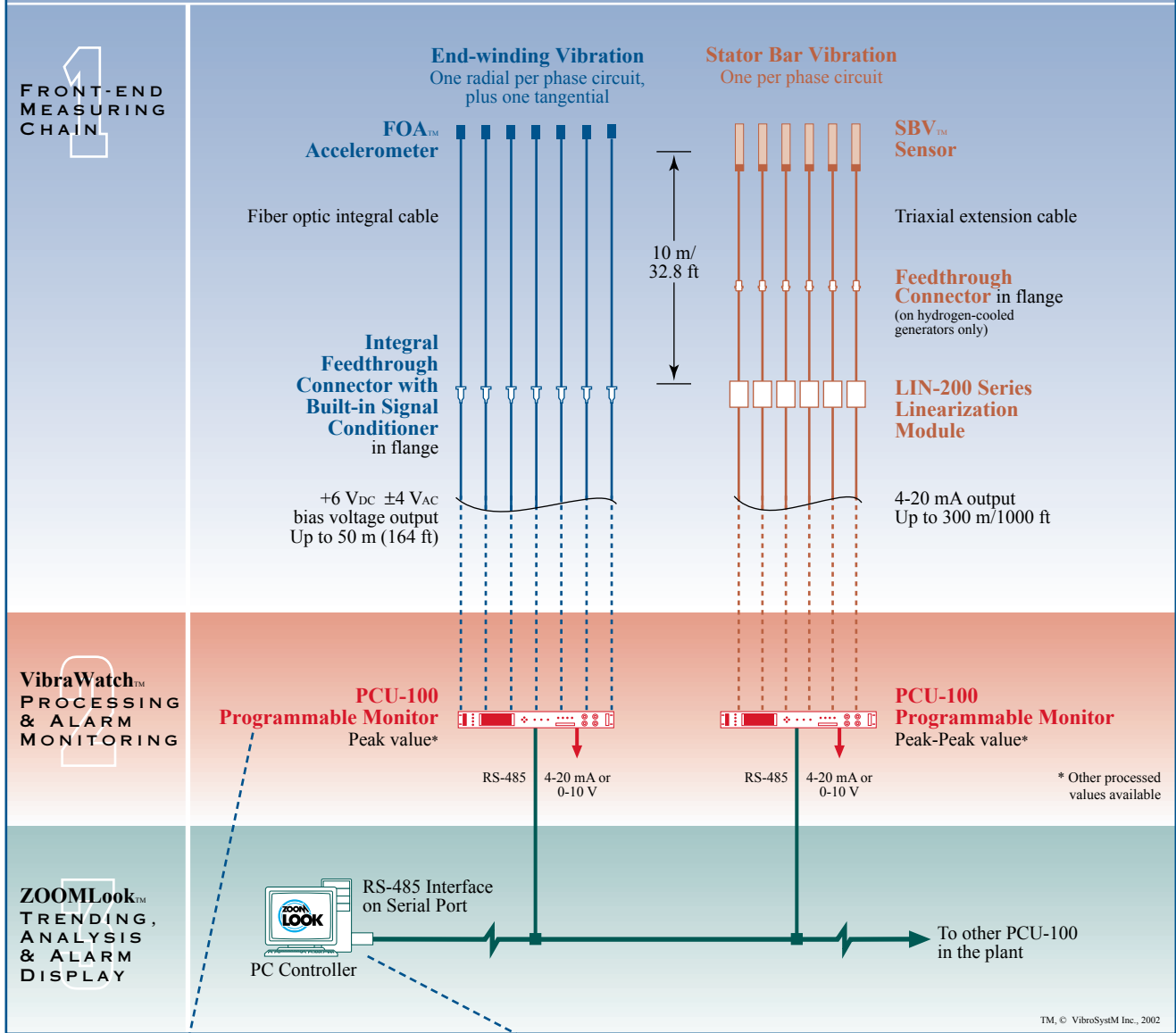

DIAGRAM OF MEASURING CHAIN AND INSTRUMENTATION PER GENERATOR END (EXCITER AND TURBINE ENDS)



TM, © VibroSYSTEM Inc., 2002

2 SIGNAL PROCESSING AND ALARM MONITORING



The PCU-100 Programmable Monitor accepts up to 8 FOA and SBV inputs, processes signals independently (raw, peak, peak-peak, rms or average value), monitors each input for dual level alarms, provides RS-485 digital output for ZOOMLook and 4-20 mA or 0-10 V analog outputs for other uses.

3 TREND MONITORING AND ANALYSIS, ALARM DISPLAY

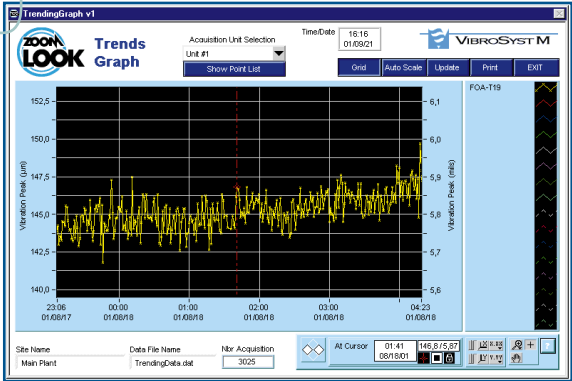

The ZOOMLook software supports up to 31 PCU-100 connections, acquires data for trending at user-defined intervals, displays trend graphs, displays monitoring and alarm statuses of each input and connected PCU-100.

STATOR WINDING VIBRATION MEASURING SYSTEM

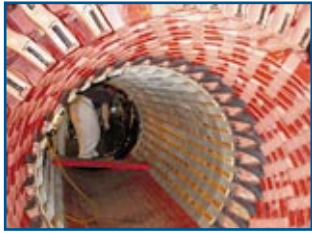

Turbogenerators

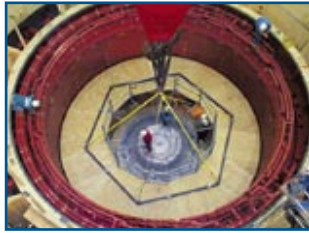

Hydrogenerators



Large Electric Motors



VibroSystM's innovative winding vibration technologies¹ are proven effective and reliable on different types of large rotating electric machines such as turbogenerators, hydroelectric pump/generators and large industrial motors. **FOA™ and SBV™ have been installed on machines worldwide since the early 1990's.**



Some justifications to install these products include: winding problems (weak support system, loose wedging and bracing, bar rupture, cooling leaks, material powdering, etc.), warranty verification (new and refurbished generators), design concerns (horizontal machines, high RPM, long end-windings, operating temperature), operations constraints (base vs. peak load, thermal cycling/cold running from frequent starts and stops, reversed stress between pump and generator modes), and maintenance practices (condition-based or preventive maintenance).

To enquire about the full extent of benefits from winding vibration monitoring and products, **contact us at:**



VIBROSYSTM

YOUR MACHINE CONDITION MONITORING PARTNER



2727 Jacques-Cartier East Blvd Longueuil (Quebec) Canada J4N 1L7
Phone: (450) 646-2157 or 1-800-663-8379 (U.S. toll free) Fax: (450) 646-2164 E-mail: sales@vibrosystem.com

WWW.VIBROSYSTEM.COM