



FOA-100E

FIBER-OPTIC ACCELEROMETER
EXTENDED FREQUENCY RANGE



APPLICATIONS

- On-line vibration monitoring in hazardous environments:
 - high voltage, severe electromagnetic interferences, and highly explosive gas.
- Electrical machine applications **up to class H (180°C/356°F)**
 - end-windings, windings, and in-slots bars,
 - electrical motor brushes,
 - isolated turbo-generator bearings,
 - high voltage circuit breakers and transformers.
- On-line vibration monitoring in fluids:
 - fuel systems
 - oils
 - water

DESCRIPTION

The FOA-100E™ (Extended Frequency Range) Optical Accelerometer is, by design, non-conductive and immune to electromagnetic interferences. It is used for hazardous environments **up to 180°C/356°F**. Its optical link ensures an excellent electrical insulation between the sensor and the instrumentation. Its passive technology makes it ideal for vibration measurements in areas where conventional piezo-electric, piezo-resistive accelerometers or any accelerometers with metallic parts may create hazards to machine and personnel, and impair reliable operation. It represents a **rugged** solution for industrial applications.

The optical sensor body is made of a high performance material with **no metallic elements**. The optical fibers of the cable are embedded and protected by an integral tubing. The sealed feedthrough connector houses the opto-electronic and conditioning circuitry. External power supply is required. The **FOA-100™ sensors family is extensively used for end-winding monitoring of Hydrogen and Air Cooled generators since 1996.** Dual-axis model also available from VibroSystM.

FEATURES

- Insulation: 3 kVAC/mm @ 25°C/77°F, 25 % of relative humidity
- Light weight sensor head made of **non-metallic parts** capable of withstanding temperature up to **180°C/356°F**
- Sealed feedthrough connector / conditioner
- Unresponsive to magnetic and electrical fields
- Low transversal sensitivity; Very good thermal stability
- Frequency range: **10-1000 Hz (-3dB)**
- Dynamic range: 0 to 40g /2 mm pk-pk @ 100 Hz or 1.4 mm pk-pk @ 120 Hz
- Bias voltage output: +6 VDC
- Sensitivity: 100 mV/g
- Integral optical cable length: 10 m/32'8" (Standard) **(Other lengths also available upon request)**
- Contains no chemical or rare earth elements, no strain or pressure constraints. Does not use fiber Bragg grating (FBG) technique.
- Calibration is traceable to National Institute of Standard and Technology (NIST),
- **ATEX certified**

DIMENSIONS

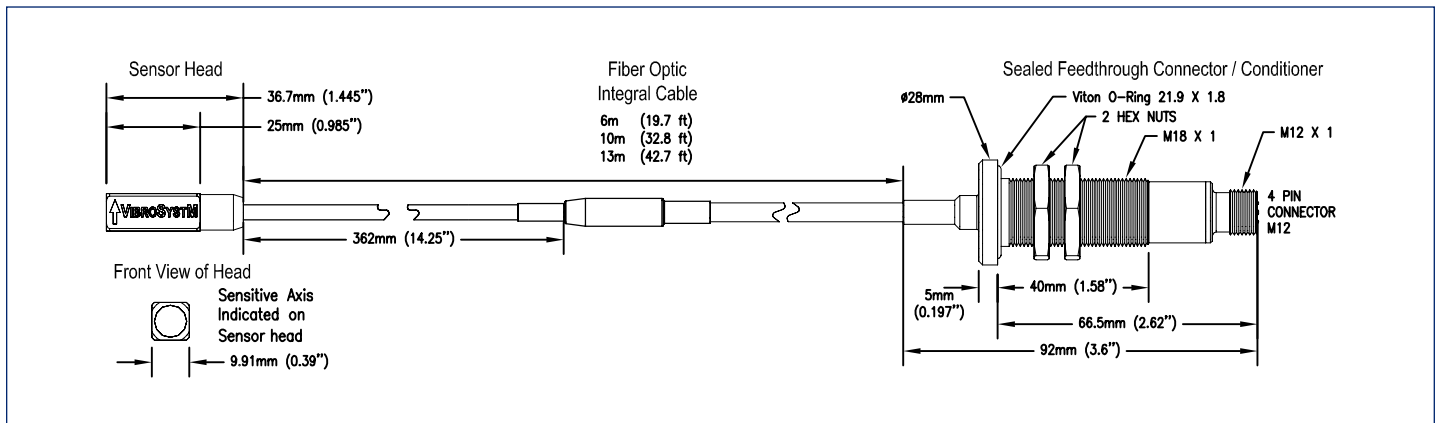



FOA-100E GENERAL SPECIFICATION

Operating

- Sensitivity 100 mV/g \pm 5% at 120 Hz
- Measuring Range 0 to 40g
2 mm [79 mils] pk-pk at 100 Hz
1.4 mm [55 mils] pk-pk at 120 Hz
- Frequency Range 10 to 1000 Hz (-3 dB)
- Output Single ended DC coupling,
bias voltage + 6 V_{DC} \pm 5%
- Max. Shock Acceleration 600g half sine or
1000g half sine,
duration 1 ms
- Resonance Frequency >2 kHz
- Transverse Sensitivity < 5% with respect to
sensitive axis
- Residual Noise < 6 mVRMS overall noise
- Resolution < 2 μ m peak-peak at 100 Hz
- Insulation Voltage 3 kVAC/mm @ 25°C/77°F,
Between Sensor Head
and Electronics 25 % of relative humidity
- Operating Pressure 700 kPa/101.5 PSI hydrogen
(withstanding pressure
test up to 1050 kPa/152.25 PSI
helium)
- Power Supply External
+ 24 V_{DC} non-stabilized
 \pm 20%, approx. 30 mA

Environmental

- Temperature Range
- Operation
 - Class A** -40° to 105°C/-40° to 221°F
 - Class F** -40° to 155°C/-40° to 311°F
 - Class H** -40° to 180°C/-40° to 356°F
- Electronics 0° to 70°C
(32° to 158°F)
- Non-destructive Sensor -50° to 200°C
(-58° to 392°F)
- Electronics -20° to 85°C
(-4° to 185°F)
- Magnetic Field No effect (head only)
- Electrical Field No effect (head only)

Physical Characteristics

- Sensor Head High Temperature Polymer
 - Length 36.70 mm (1.45 in.)
 - Width 9.91 mm (0.39 in.)
 - Thickness 9.91 mm (0.39 in.)
 - Weight 4.70 g (0.17 oz.)
- Sealed Feedthrough Chromed Brass alloy,
M12 4-Pin connector on outside
end with mating shielded connector,
Viton O-ring 21.95 x 1.78,
2 hex nuts M18x1
 - Length 92 mm (3.62 in.)
 - Max. Diameter 28 mm (1.10 in.)
 - Thread Length 35 mm (1.38 in.)
 - Thread Diameter 18 mm (0.71 in.)
 - Weight 120 g (4.23 oz.)
- Integral Cable Optical fibers with PTFE
protection tubing
 - **Standard Length** 10 m (32.80 ft)
Other lengths also available upon request
 - Diameter 4.76 mm (0.19 in.)
 - Min. Bending Radius 80 mm (3.15 in.)

DIAGRAM

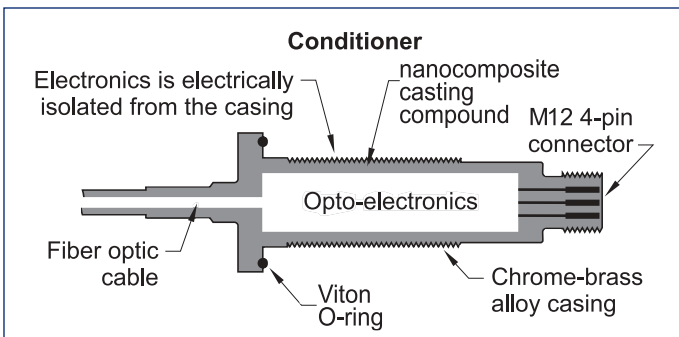



FOA GENERAL SPECIFICATION OVERVIEW

FIBER OPTIC ACCELEROMETER	TEMPERATURE RANGE	FREQUENCY RANGE	CABLE LENGTH
FOA-100 (Single Axis)	STANDARD -40° to 90°C <i>-40° to 194°F</i>	30 to 350 Hz (± 10%)	STANDARD 10 meters/32.80 ft
	CLASS F -40° to 155°C <i>-40° to 311°F</i>		
	CLASS H -40° to 180°C <i>-40° to 356°F</i>		
FOA-100E (Single Axis, Extended Frequency Range)	CLASS A -40° to 105°C <i>-40° to 221°F</i>	10 to 1000 Hz (-3 dB)	STANDARD 10 meters/32.80 ft
	CLASS F -40° to 155°C <i>-40° to 311°F</i>		
	CLASS H -40° to 180°C <i>-40° to 356°F</i>		
FOA-200 (Dual-Axis)	STANDARD -40° to 90°C <i>-40° to 194°F</i>	10 to 1000 Hz (-3 dB)	STANDARD 10 meters/32.80 ft
	CLASS F -40° to 155°C <i>-40° to 311°F</i>		
	CLASS H -40° to 180°C <i>-40° to 356°F</i>		